

Document Title	HSD103KPW2-A10 Formal Specification	Page No.	1 / 26
Document No.	DC140-002952	Revision	1.0

TO :

Date : Jul., 23, 2018

HannStar Product Specification

(Formal)

Model: HSD103KPW2 – A10
10.25” Color TFT-LCD Module

Note:

- (1) Please contact HannStar Display Corp. before designing your product based on this module specification.
- (2) The information contained herein is presented merely to indicate the characteristics and performance of our products. No responsibility is assumed by HannStar for any intellectual property claims or other problems that may result from application based on the module described herein.
- (3) The mark “**” of Model means sub-model code.

Document Title	HSD103KPW2-A10 Formal Specification	Page No.	2 / 26
Document No.	DC140-002952	Revision	1.0

Record of Revisions

Rev.	Date	Sub-Model	Description of change
1.0	Jul. 23, 2018	A10	Formal Specification was first released.

Document Title	HSD103KPW2-A10 Formal Specification	Page No.	3 / 26
Document No.	DC140-002952	Revision	1.0

Contents

1.0 GENERAL DESCRIPTION	4
2.0 ABSOLUTE MAXIMUM RATINGS	5
3.0 OPTICAL CHARACTERISTICS	6
4.0 BLOCK DIAGRAM.....	11
5.0 INTERFACE PIN CONNECTION	13
6.0 ELECTRICAL CHARACTERISTICS.....	16
7.0 RELIABILITY TEST ITEMS	20
8.0 OUTLINE DIMENSION.....	21
9.0 LOT MARK.....	23
10.0 PACKAGE SPECIFICATION	24
11.0 GENERAL PRECAUTION.....	25

Document Title	HSD103KPW2-A10 Formal Specification	Page No.	4 / 26
Document No.	DC140-002952	Revision	1.0

1.0 GENERAL DESCRIPTION

1.1 Introduction

HannStar Display model HSD103KPW2-A10 is a color active matrix thin film transistor (TFT) liquid crystal display (LCD) that uses amorphous silicon TFT as a switching device. This model is composed of a TFT LCD panel, a driving circuit and a back light system. This TFT LCD has a 10.25 inch diagonally measured active display area with HD (1920 horizontal by 720 vertical pixel) resolution.

1.2 Features

- 10.25 (8:3 diagonal) inch configuration
- 16.7M LVDS (two port)
- ROHS / Halogen Free Compliance

1.3 Applications

- Automotive

1.4 General information

Item	Specification	Unit	
Outline Dimension	259.8 (H) x 112.0 (V) x 8.5 (D) (Typ)	mm	
Display area	243.648(H) x 91.368(V) (10.25" diagonal)	mm	
Number of Pixel	1920(H) x 720(V)	pixels	
Pixel pitch	0.1269(H) x 0.1269(V)	mm	
Pixel arrangement	RGB Vertical Stripe		
Display mode	Normally Black		
NTSC	70 (Typ.)	%	
Surface treatment	Antiglare, Hard-Coating (3H)		
Weight	360	g	
Back-light	Single LED (Side-Light type)		
Power Consumption	Logic System (White Pattern)	2 (max)	W
	B/L System	7.722 (Max.)	W

1.5 Mechanical Information

Item		Min.	Typ.	Max.	Unit
Module Size	Horizontal (H)	259.4	259.8	260.2	mm
	Vertical (V)	111.6	112.0	112.4	mm
	Depth (D)	8.3	8.5	8.8	mm
Weight		—	360	—	g

Document Title	HSD103KPW2-A10 Formal Specification	Page No.	5 / 26
Document No.	DC140-002952	Revision	1.0

2.0 ABSOLUTE MAXIMUM RATINGS

2.1 Electrical Absolute Rating

2.1.1 TFT LCD Module

Item	Symbol	Min.	Max.	Unit	Note
Logic Supply Voltage	VDD	-0.3	+5.0	V	-

2.2 Environment Absolute Rating

Item	Symbol	Min.	Max.	Unit	Note
Operating Temperature	T _{opa}	-30	85	°C	
Storage Temperature	T _{stg}	-40	90	°C	

Document Title	HSD103KPW2-A10 Formal Specification	Page No.	6 / 26
Document No.	DC140-002952	Revision	1.0

3.0 OPTICAL CHARACTERISTICS

3.1 Optical specification

Item		Symbol	Condition	Min.	Typ.	Max.	Unit	Note	
Contrast		CR	Normal viewing angle	800	1000	—		(1)(2)	
Response time	25°C	TR+TF		—	—	30	msec	(1)(3)	
	-20°C			—	—	250			
	-30°C			—	—	500			
White luminance (Center)		Y_L		$\Theta=0$	650	850	—	cd/m ²	(1)(4) ($I_L=240mA$)
Color chromaticity (CIE1931)	White	W_x		Normal viewing angle	0.273	0.313	0.353		(1)(4)
		W_y			0.289	0.329	0.369		
	Red	R_x			—	0.647	—		
		R_y			—	0.333	—		
	Green	G_x			—	0.293	—		
		G_y	—		0.611	—			
Blue	B_x	—	0.148	—					
	B_y	—	0.059	—					
Viewing angle	Hor.	Θ_L	CR>10	80	85	—			
		Θ_R		80	85	—			
	Ver.	Θ_U		80	85	—			
		Θ_D		80	85	—			
Brightness uniformity		B_{UNI}	$\Theta=0$	75	80	—	%	(5)	
Optima View Direction		Free						(6)	
Reflection	%	R (%)	—	—	5.0	5.5	%	(7)	

3.2 Measuring Condition

- Measuring surrounding : dark room
- LED current I_L : 240mA
- Ambient temperature : 25±2°C
- 15min. warm-up time.

Document Title	HSD103KPW2-A10 Formal Specification	Page No.	7 / 26
Document No.	DC140-002952	Revision	1.0

3.3 Measuring Equipment

- FPM520 of Westar Display technologies, INC., which utilized SR-3 for Chromaticity and BM-5A for other optical characteristics.

- Measuring spot size : 20 ~ 21 mm

Note (1) Definition of Viewing Angle:

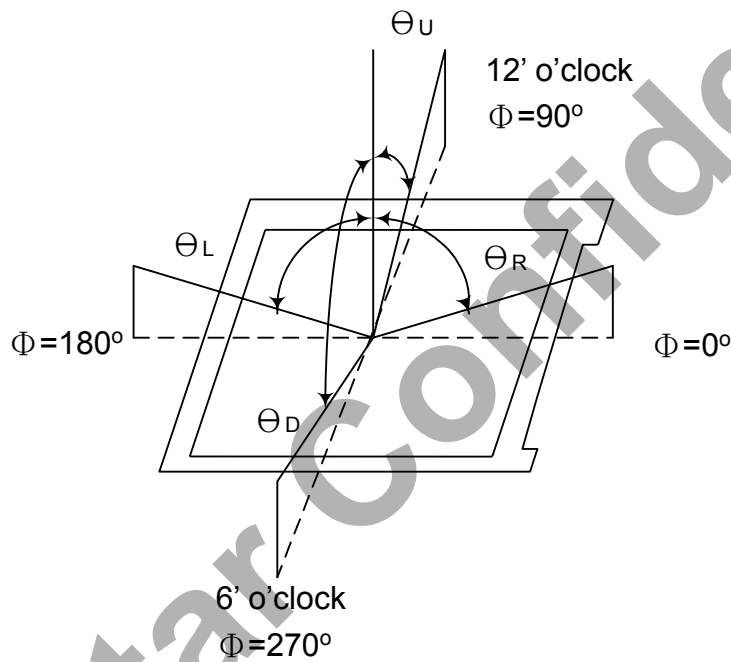

Note (2) Definition of Contrast Ratio (CR) :
measured at the center point of panel

$$CR = \frac{\text{Luminance with all pixels white}}{\text{Luminance with all pixels black}}$$

Document Title	HSD103KPW2-A10 Formal Specification	Page No.	8 / 26
Document No.	DC140-002952	Revision	1.0

Note (3) Definition of Response Time : Sum of T_R and T_F

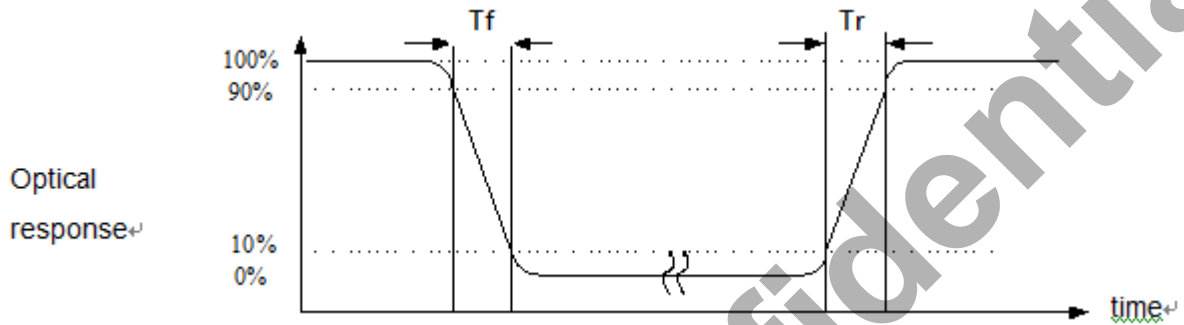

Note (4) Definition of optical measurement setup

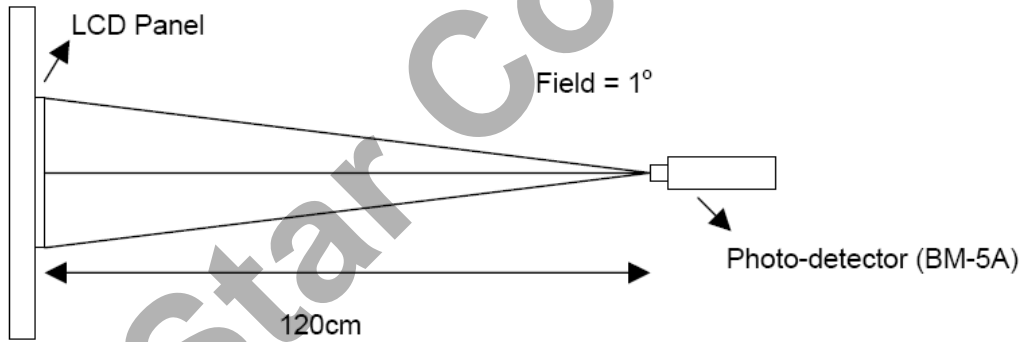

Document Title	HSD103KPW2-A10 Formal Specification	Page No.	9 / 26
Document No.	DC140-002952	Revision	1.0

Note (5) Definition of brightness uniformity

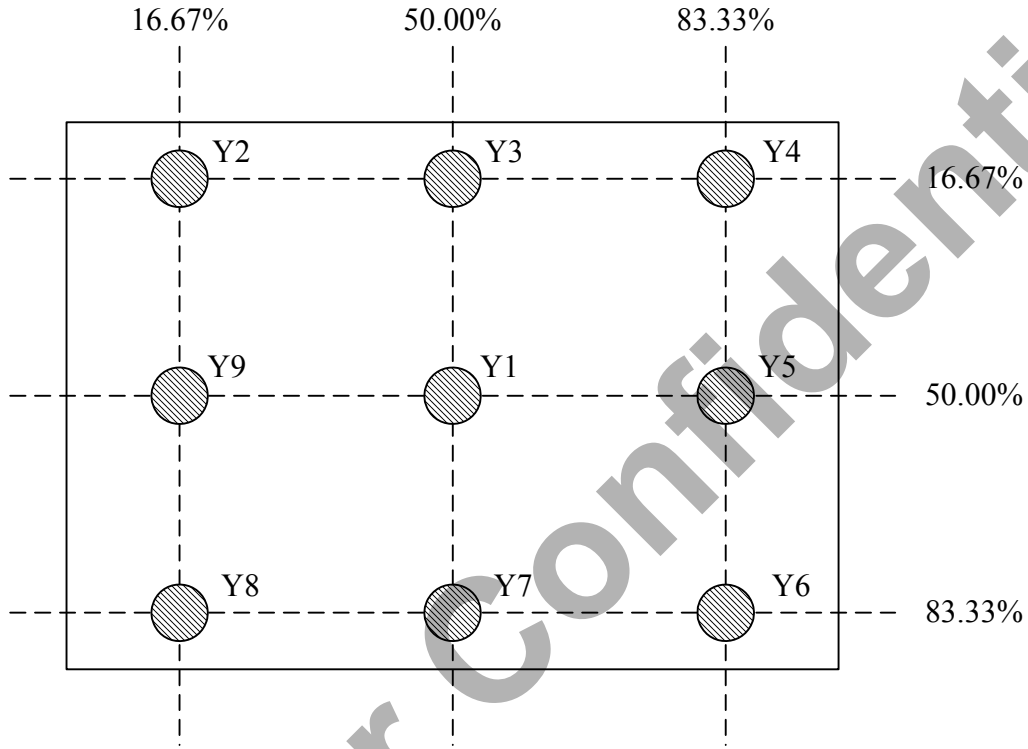

$$\text{Luminance uniformity} = \frac{\text{(Min Luminance of 9 points)}}{\text{(Max Luminance of 9 points)}} \times 100\%$$

Note (6) : Rubbing Direction (The different Rubbing Direction will cause the different optima view direction.)

Document Title	HSD103KPW2-A10 Formal Specification	Page No.	10 / 26
Document No.	DC140-002952	Revision	1.0

Note (7) Definition of CM-3700A(Konica Minolta) Measurement specification

- The Settings of the instrument :
 - A. reflection rate;
 - B. Measuring the aperture: MAV(8mm);
 - C. Observer perspective: 2°;
 - D. Specular light: SCI;
 - E. The light source: D65.

- The definition of measurement way
 Chromatic meter will display the absorption of shaft and spectral type axial parallel alignment, and placed the sample frame for photometry.

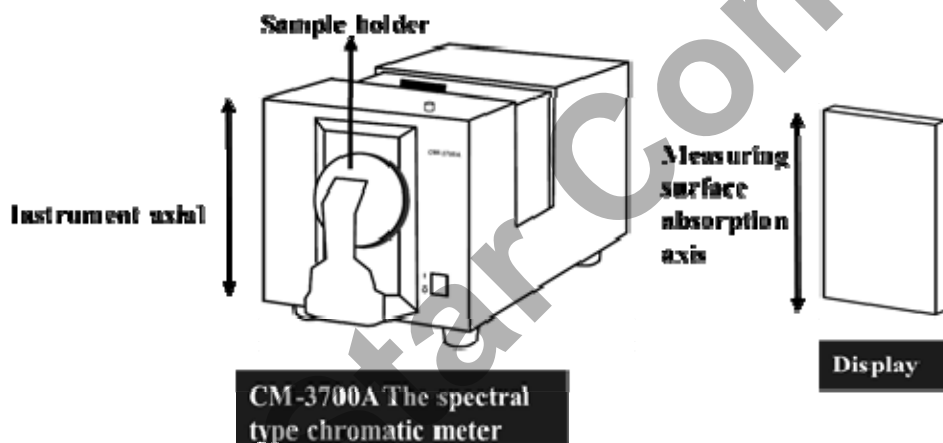

Document Title	HSD103KPW2-A10 Formal Specification	Page No.	11 / 26
Document No.	DC140-002952	Revision	1.0

4.0 BLOCK DIAGRAM

4.1 TFT LCD Module:

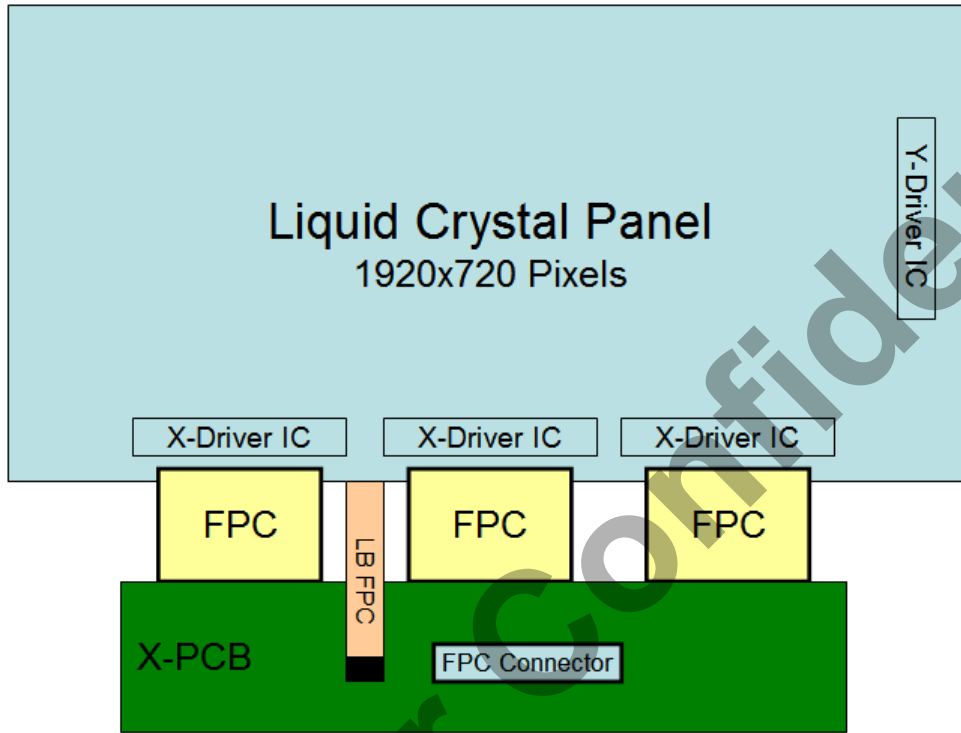

4.2 Pixel Format

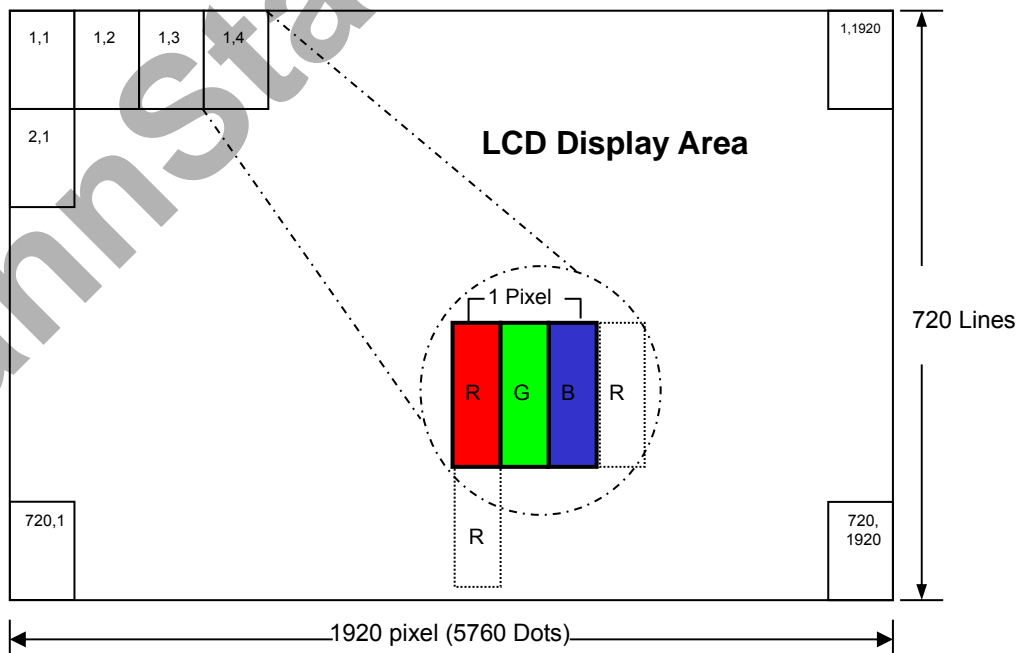

Document Title	HSD103KPW2-A10 Formal Specification	Page No.	12 / 26
Document No.	DC140-002952	Revision	1.0

4.3 Relationship Between Displayed Color and Input

	Display	MSB				LSB				MSB				LSB				MSB				LSB				Gray scale Level
		R7	R6	R5	R4	R3	R2	R1	R0	G7	G6	G5	G4	G3	G2	G1	G0	B7	B6	B5	B4	B3	B2	B1	B0	
Basic color	Black	L	L	L	L	L	L	L	L	L	L	L	L	L	L	L	L	L	L	L	L	L	L	L	L	-
	Blue	L	L	L	L	L	L	L	L	L	L	L	L	L	L	L	L	H	H	H	H	H	H	H	H	-
	Green	L	L	L	L	L	L	L	L	H	H	H	H	H	H	H	H	L	L	L	L	L	L	L	L	-
	Light Blue	L	L	L	L	L	L	L	L	H	H	H	H	H	H	H	H	H	H	H	H	H	H	H	H	-
	Red	H	H	H	H	H	H	H	H	L	L	L	L	L	L	L	L	L	L	L	L	L	L	L	L	-
	Purple	H	H	H	H	H	H	H	H	L	L	L	L	L	L	L	L	H	H	H	H	H	H	H	H	-
	Yellow	H	H	H	H	H	H	H	H	H	H	H	H	H	H	H	H	L	L	L	L	L	L	L	L	-
	White	H	H	H	H	H	H	H	H	H	H	H	H	H	H	H	H	H	H	H	H	H	H	H	H	-
Gray scale of Red	Black	L	L	L	L	L	L	L	L	L	L	L	L	L	L	L	L	L	L	L	L	L	L	L	L	L0
	Dark	L	L	L	L	L	L	L	H	L	L	L	L	L	L	L	L	L	L	L	L	L	L	L	L	L1
		L	L	L	L	L	L	H	L	L	L	L	L	L	L	L	L	L	L	L	L	L	L	L	L	L2
		:	:	:	:	:	:	:	:	:	:	:	:	:	:	:	:	:	:	:	:	:	:	:	:	L3...L251
	Light	H	H	H	H	H	H	L	L	L	L	L	L	L	L	L	L	L	L	L	L	L	L	L	L	L252
		H	H	H	H	H	H	L	H	L	L	L	L	L	L	L	L	L	L	L	L	L	L	L	L	L253
		H	H	H	H	H	H	H	L	L	L	L	L	L	L	L	L	L	L	L	L	L	L	L	L	L254
Red	H	H	H	H	H	H	H	H	L	L	L	L	L	L	L	L	L	L	L	L	L	L	L	L	Red L255	
Gray scale of Green	Black	L	L	L	L	L	L	L	L	L	L	L	L	L	L	L	L	L	L	L	L	L	L	L	L	L0
	Dark	L	L	L	L	L	L	L	H	L	L	L	L	L	L	L	L	L	L	L	L	L	L	L	L	L1
		L	L	L	L	L	L	H	L	L	L	L	L	L	L	L	L	L	L	L	L	L	L	L	L	L2
		:	:	:	:	:	:	:	:	:	:	:	:	:	:	:	:	:	:	:	:	:	:	:	:	L3...L251
	Light	L	L	L	L	L	L	L	L	H	H	H	H	H	L	L	L	L	L	L	L	L	L	L	L252	
		L	L	L	L	L	L	L	H	L	L	L	L	L	L	L	L	L	L	L	L	L	L	L	L253	
		L	L	L	L	L	L	L	H	H	H	H	H	H	L	L	L	L	L	L	L	L	L	L254		
Green	L	L	L	L	L	L	L	L	H	H	H	H	H	H	H	L	L	L	L	L	L	L	L	Green L255		
Gray scale of Blue	Black	L	L	L	L	L	L	L	L	L	L	L	L	L	L	L	L	L	L	L	L	L	L	L	L	L0
	Dark	L	L	L	L	L	L	L	L	L	L	L	L	L	L	L	L	L	L	L	L	L	L	L	L	L1
		L	L	L	L	L	L	L	H	L	L	L	L	L	L	L	L	L	L	L	L	L	L	L	L2	
		:	:	:	:	:	:	:	:	:	:	:	:	:	:	:	:	:	:	:	:	:	:	:	L3...L251	
	Light	L	L	L	L	L	L	L	L	L	L	L	L	L	L	L	L	H	H	H	H	H	L	L	L252	
		L	L	L	L	L	L	L	L	L	L	L	L	L	L	L	L	H	H	H	H	H	L	H	L253	
		L	L	L	L	L	L	L	L	L	L	L	L	L	L	L	L	H	H	H	H	H	H	L	L254	
Blue	L	L	L	L	L	L	L	L	L	L	L	L	L	L	L	L	H	H	H	H	H	H	H	Blue L255		
Gray scale of White & Black	Black	L	L	L	L	L	L	L	L	L	L	L	L	L	L	L	L	L	L	L	L	L	L	L	L	L0
	Dark	L	L	L	L	L	L	L	H	L	L	L	L	L	L	H	L	L	L	L	L	L	L	H	L1	
		L	L	L	L	L	L	H	L	L	L	L	L	L	H	L	L	L	L	L	L	L	H	L	L2	
		:	:	:	:	:	:	:	:	:	:	:	:	:	:	:	:	:	:	:	:	:	:	:	L3...L251	
	Light	H	H	H	H	H	L	L	H	H	H	H	H	L	L	H	H	H	H	H	L	L	L252			
		H	H	H	H	H	L	H	H	H	H	H	L	H	H	H	H	H	L	H	L253					
		H	H	H	H	H	H	L	H	H	H	H	H	L	H	H	H	H	H	L	L254					
White	H	H	H	H	H	H	H	H	H	H	H	H	H	H	H	H	H	H	H	H	H	H	H	White L255		

Document Title	HSD103KPW2-A10 Formal Specification	Page No.	13 / 26
Document No.	DC140-002952	Revision	1.0

5.0 INTERFACE PIN CONNECTION

5.1 FPC Pin Assignment:

FPC connector is used for electronics interface. The recommended model is CN1 (Input signal): IRISO 12003S-50Y900

Pin NO.	Symbol	I/O	Description	Note
1	GND	P	Ground	
2	VDD	P	External main and I/O power supply ; +3.3V	
3	VDD	P	External main and I/O power supply ; +3.3V	
4	NC	-	Keep floating	
5	RESET	I	Global reset pin RESET="H",normal operation.(Default) RESET="L",LCM is in reset state.	
6	STBYB	I	Standby mode control. STBYB="H",normal operation. STBYB="L",LCM is in standby state.(Default)	
7	GND	P	Ground	
8	OLV0N	I	LVDS odd data 0-	
9	OLV0P	I	LVDS odd data 0+	
10	GND	P	Ground	
11	OLV1N	I	LVDS odd data 1-	
12	OLV1P	I	LVDS odd data 1+	
13	GND	P	Ground	
14	OLV2N	I	LVDS odd data 2-	
15	OLV2P	I	LVDS odd data 2+	
16	GND	P	Ground	
17	OLVCLKN	I	LVDS odd clk -	
18	OLVCLKP	I	LVDS odd clk +	
19	GND	P	Ground	
20	OLV3N	I	LVDS odd data 3-	
21	OLV3P	I	LVDS odd data 3+	
22	GND	P	Ground	
23	ELV0N	I	LVDS even data 0-	
24	ELV0P	I	LVDS even data 0+	
25	GND	P	Ground	
26	ELV1N	I	LVDS even data 1-	
27	ELV1P	I	LVDS even data 1+	
28	GND	P	Ground	

Document Title	HSD103KPW2-A10 Formal Specification	Page No.	14 / 26
Document No.	DC140-002952	Revision	1.0

29	ELV2N	I	LVDS even data 2-
30	ELV2P	I	LVDS even data 2+
31	GND	P	Ground
32	ELVCLKN	I	LVDS even clk -
33	ELVCLKP	I	LVDS even clk +
34	GND	P	Ground
35	ELV3N	I	LVDS even data 3-
36	ELV3P	I	LVDS even data 3+
37	GND	P	Ground
38	GND	P	Ground
39	RL	I	Horizontal shift direction (source output) selection. RL = "H": Left -> Right(default) RL = "L": Right -> Left
40	TB	I	Vertical shift direction (gate output) selection. TB = "H": Top ->Bottom (default) TB = "L": Bottom->Top
41	NC	-	Keep floating
42	NC	-	Keep floating,internal used for LCM maker.
43	NC	-	Keep floating
44	VDD	P	External main and I/O power supply ; +3.3V
45	NC	-	Keep floating,internal used for LCM maker.
46	NC	-	Keep floating,internal used for LCM maker.
47	NC	-	Keep floating,internal used for LCM maker.
48	NC	-	Keep floating,internal used for LCM maker.
49	NC	-	Keep floating,internal used for LCM maker.
50	NC	-	Keep floating,internal used for LCM maker.

Note 1 : UPDN and SHLR control function

SHLR	UPDN	Data shifting
DVDD	GND	Left→Right→Down→Up
GND	GND	Right→Left ; Down→Up
DVDD	DVDD	Left→Right ; Up→Down(default)
GND	DVDD	Right→Left ; Up→Down

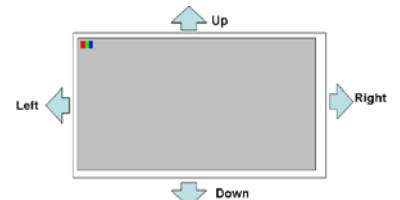

Document Title	HSD103KPW2-A10 Formal Specification	Page No.	15 / 26
Document No.	DC140-002952	Revision	1.0

5.2 LED Board Pin Assignment:

CN2: IRISO 12001S-10Y901

Pin NO.	Symbol	Description
1	PLED	Power LED anode power supply
2	PLED	Power LED anode power supply
3	PLED	Power LED anode power supply
4	NC	
5	NTC1	heat sensor
6	NTC2(GND)	heat sensor
7	NLED	Power LED cathode power supply
8	NLED	Power LED cathode power supply
9	NLED	Power LED cathode power supply
10	NLED	Power LED cathode power supply

Document Title	HSD103KPW2-A10 Formal Specification	Page No.	16 / 26
Document No.	DC140-002952	Revision	1.0

6.0 ELECTRICAL CHARACTERISTICS

6.1 TFT LCD Module

Item	Symbol	Min.	Typ.	Max.	Unit	Note
Supply Voltage	VDD	+3.0	+3.3	+3.6		Note (1)
Input Signal Voltage	V_{IH}	$0.7 \times VDD$	-	VDD	V	Note (2)
	V_{IL}	GND	-	$0.3 \times VDD$	V	
Current of VDD	IDD	-	-	600	mA	@White Pattern

Note :

(1) : VDD setting should match the signals output voltage of customer's system board.

(2) : RESET, STBYB, R/L, T/B

6.2 Switching Characteristics for LVDS Receiver

Item	Symbol	Min.	Typ.	Max.	Unit	Conditions
Differential Input High Threshold	R_{xVTH}	+100		+300	mV	
Differential Input Low Threshold	R_{xVTL}	-300		-100	mV	
Differential input common mode voltage	R_{xVCM}	1.0	1.2	$1.7 - V_{ID} /2$	V	
Input leakage Current	I_{IN}	-10		10	uA	RX+/-, RXC+/-
Differential input Voltage	$ V_{ID} $	200		600	mV	

Single-end Signal

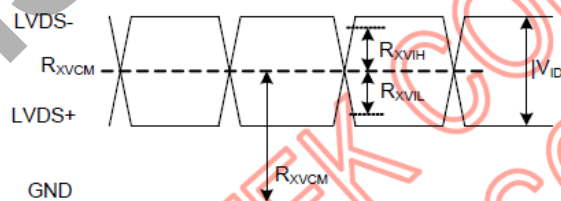

Differential Signal

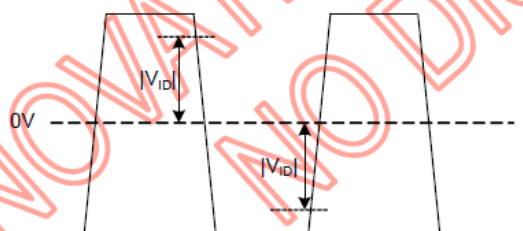

Document Title	HSD103KPW2-A10 Formal Specification	Page No.	17 / 26
Document No.	DC140-002952	Revision	1.0

6.3 8Bit LVDS input

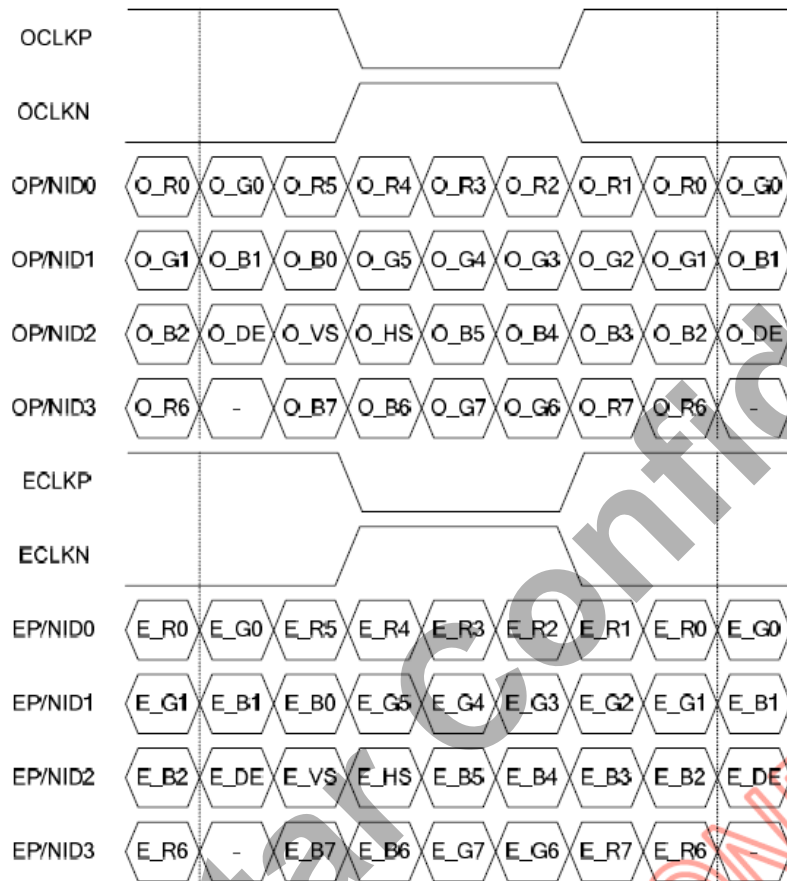

6.4 Interface Timing (DE mode)

Item	Symbol	Min.	Typ.	Max.	Unit
Frame Rate	--	55	60	65	Hz
Vertical Total Time	T _v	730	732	764	line
Vertical Display Time	T _{vD}	720			
Vertical Blanking Time	T _{vB}	10	12	44	line
Horizontal Total Time	T _H	1022	1045	1080	clock
Horizontal Display Time	T _{HD}	960			
Horizontal Blanking Time	T _{HB}	62	85	120	clock
Clock Rate	1/ T _{clock}	45.4	45.9	48.5	MHz

Document Title	HSD103KPW2-A10 Formal Specification	Page No.	18 / 26
Document No.	DC140-002952	Revision	1.0

6.5 Power On / Off Sequence

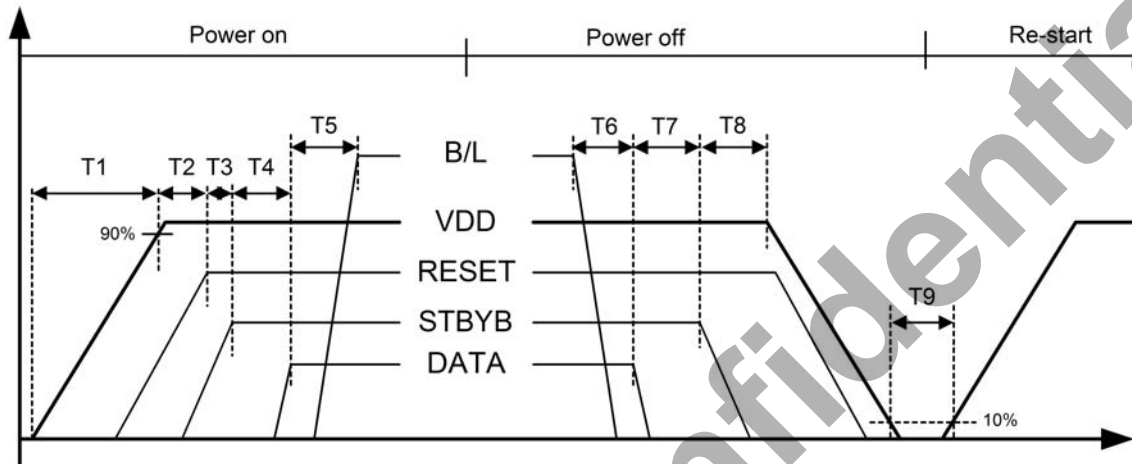

Item	Min.	Typ.	Max.	Unit
T1	0.5	--	20	ms
T2	1	--	--	ms
T3	1	--	--	ms
T4	200	--	--	ms
T5	50	--	--	ms
T6	50	--	--	ms
T7	16	--	--	ms
T8	16	--	--	ms
T9	1000	--	--	ms

Document Title	HSD103KPW2-A10 Formal Specification	Page No.	19 / 26
Document No.	DC140-002952	Revision	1.0

6.6 Backlight Unit

Parameter	Symbol	Min	Typ	Max	Units	Condition
LED Current	I_L	--	240	--	mA	$T_a=25^{\circ}\text{C}$
LED Voltage	V_L	--	27.9	29.7	Volt	$T_a=25^{\circ}\text{C}$
LED Life-Time	N/A	20,000	--	--	Hour	$T_a=25^{\circ}\text{C}$ $I_F=60\text{mA}$ Note (2)

Note (1) LED life time (Hr) can be defined as the time in which it continues to operate under the condition: $T_a=25\pm 3^{\circ}\text{C}$, typical I_L value indicated in the above table until the brightness becomes less than 50%.

Note (2) The "LED life time" is defined as the module brightness decrease to 50% original brightness at $T_a=25^{\circ}\text{C}$ and $I_L=240\text{mA}$. The LED lifetime could be decreased if operating I_L is larger than 240mA. The constant current driving method is suggested.

Note (3) LED Light Bar Circuit

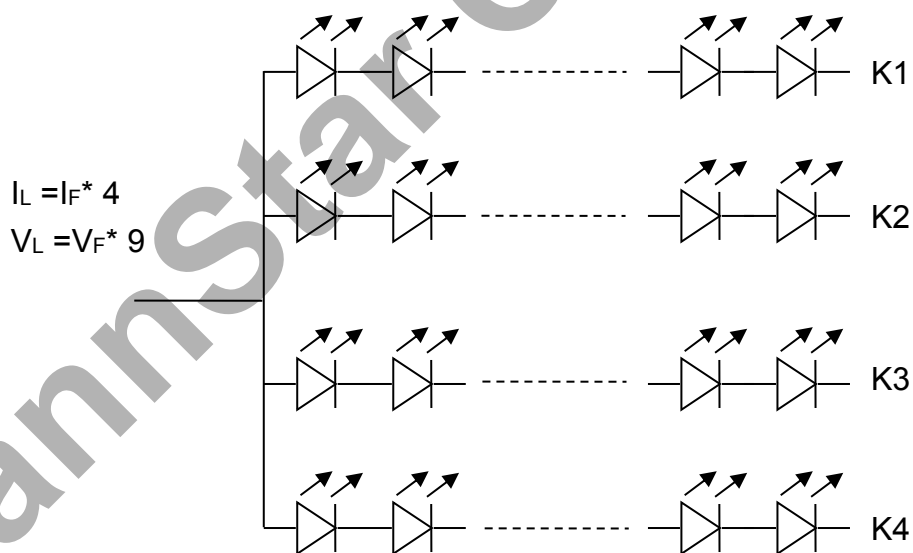

Document Title	HSD103KPW2-A10 Formal Specification	Page No.	20 / 26
Document No.	DC140-002952	Revision	1.0

7.0 RELIABILITY TEST ITEMS

No.	Item	Conditions	Remark
1	High Temperature Storage	Ta=+90°C, 500hrs	1,2,3
2	Low Temperature Storage	Ta=-40°C, 500hrs	1,2,3
3	High Temperature Operation	Ta=+85°C,500hrs	1,2,3
4	Low Temperature Operation	Ta=-30°C, 500hrs	1,2,3
5	High Temperature and High Humidity (operation)	Ta=+60°C, 90%RH, 240hrs	1,2,3
6	Thermal Cycling Test (non operation)	-30°C(30min) → +85°C(30min), 100 cycles	1,2,3
7	Electrostatic Discharge	R=330Ω,C=150pF Contact = ± 8 kV, class B; Air = ± 15 kV, class B; 1 time for each point.	
8	Vibration	1.Random: 1.04G, 10~500Hz, XYZ, 30min/each direction 2.Sine: Freq.1.5G, 8~33.3Hz, Stoke: 1.3mmhz Sweep: 2.9G, 33.3~400 X/Z: 2hrs, Y:4hrs	
9	Shock	Half-Sine, 100G, 6ms, ±XYZ, 1time	
10	Vibration (with carton)	Random: 0.015G ² /Hz, 5~200Hz -6dB/Octave, 200~400Hz XYZ 2hrs/each direction	
11	Drop (with carton)	Drop height condition, basis on the product weight and follow QB100-0027 1 corner, 3 edges, 6 surfaces	

Note1: There is no display function NG issue occurred, all the cosmetic specification is judged before the reliability stress.

Note2: The test result shall be evaluated after the sample has been left at room temperature and humidity for 2 hours without load. No condensation shall be accepted. The sample shall be free from defects:

(Air bubble in the LCD、Seal leak、Non-display、Missing segments、Glass crack).

Note3 : The test condition definition panel's surface temperature.

Document Title	HSD103KPW2-A10 Formal Specification	Page No.	21 / 26
Document No.	DC140-002952	Revision	1.0

8.0 OUTLINE DIMENSION

Unit : mm

8.1 Front View:

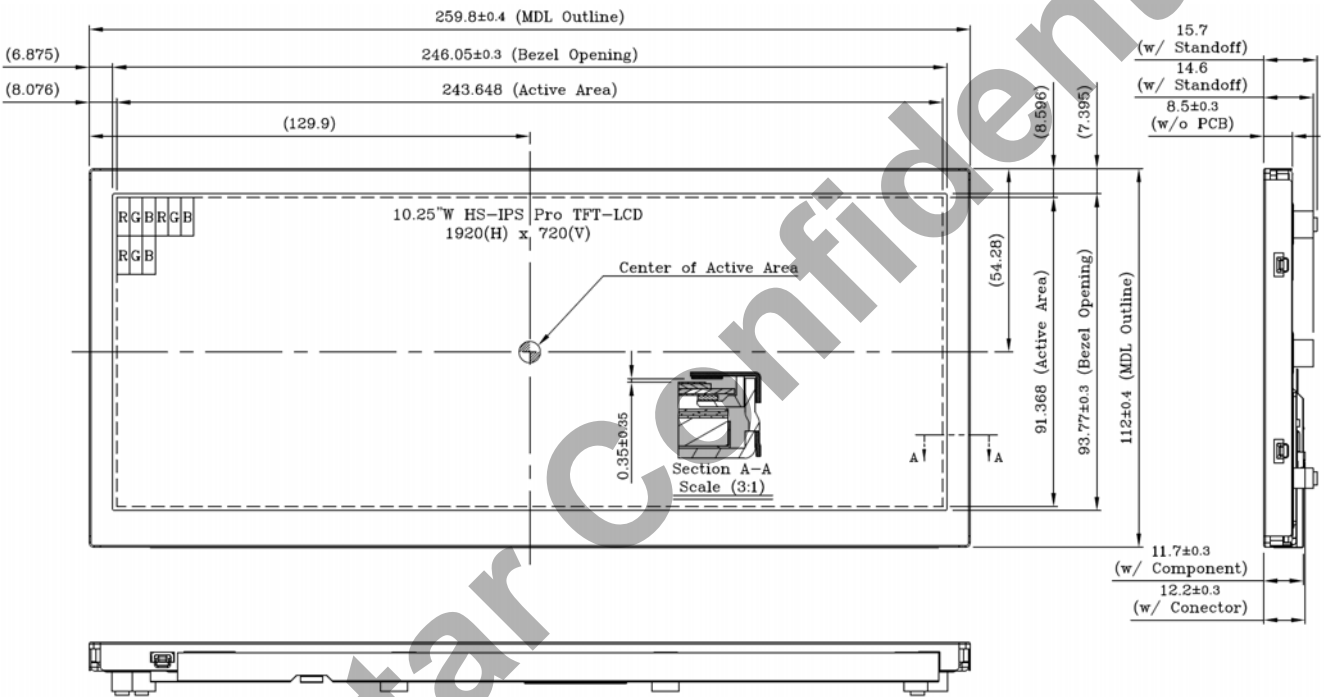

Document Title	HSD103KPW2-A10 Formal Specification	Page No.	22 / 26
Document No.	DC140-002952	Revision	1.0

8.1 Rear View:

General tolerance: $\pm 0.3\text{mm}$

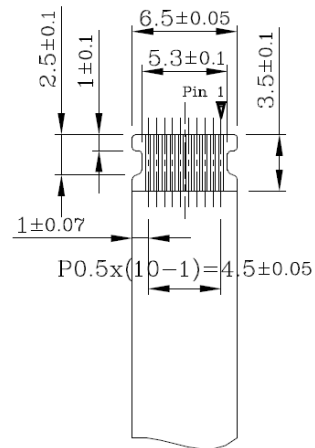
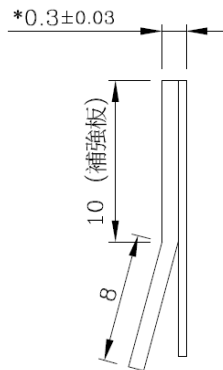
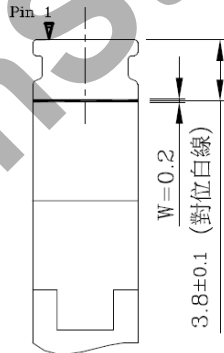
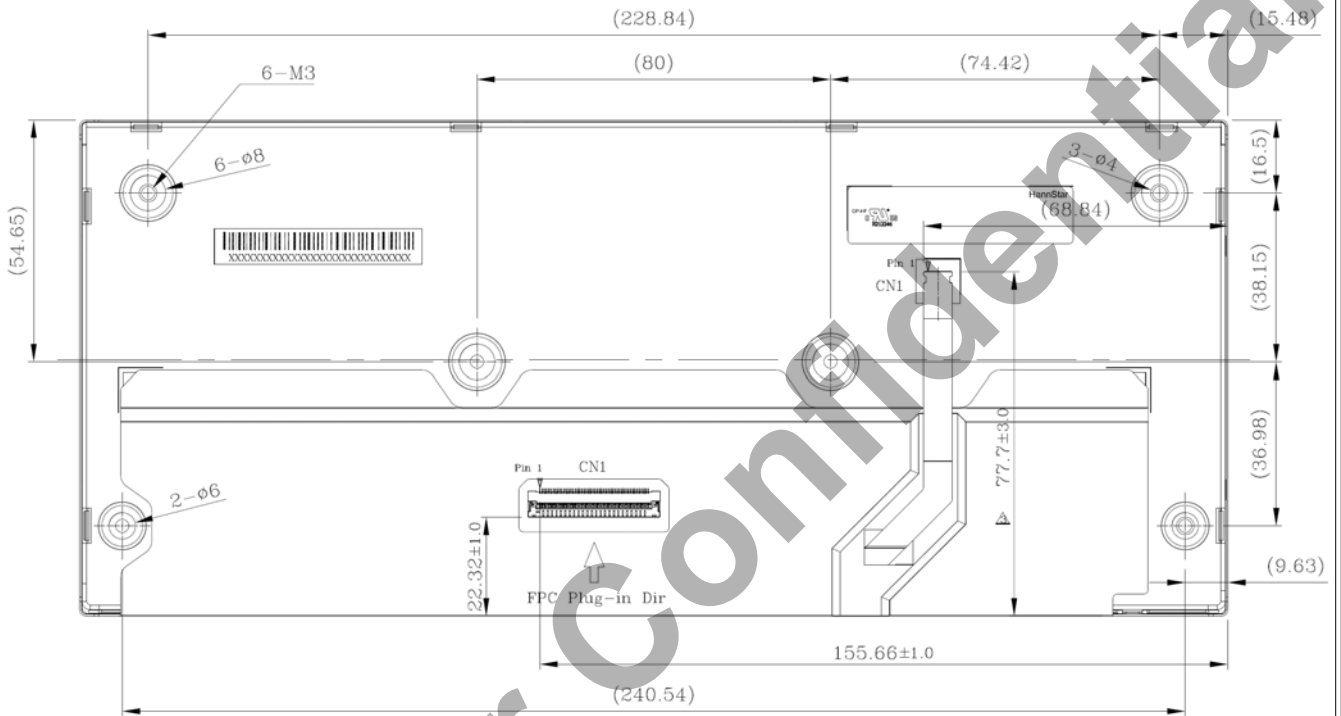

CN2(Scale: 2:1)

Document Title	HSD103KPW2-A10 Formal Specification	Page No.	23 / 26
Document No.	DC140-002952	Revision	1.0

9.0 LOT MARK

9.1 Lot Mark

1	2	3	4	5	6	7	8	9	10	11	12	13	14	15
---	---	---	---	---	---	---	---	---	----	----	----	----	----	----

Code 1,2,3,4,5,6: HannStar internal flow control code.

Code 7: production location.

Code 8: production year.

Code 9: production month.

Code 10,11,12,13,14,15: serial number.

Note (1) Production Year: Code 8 is defined by the last number of the year, for example

Year	2016	2017	2018	2019	2020	2021	2022	2023	2024	2025
Mark	6	7	8	9	0	1	2	3	4	5

Note (2) Production Month

Month	Jan.	Feb.	Mar.	Apr.	May.	Jun.	Jul.	Aug.	Sep.	Oct	Nov.	Dec.
Mark	1	2	3	4	5	6	7	8	9	A	B	C

9.2 Detail of Lot Mark

- (1) Below label is attached on the backside of the LCD module. See Section 8.0: Outline Dimension.
- (2) The detail of Lot Mark is attached as below.
- (3) This is subject to change without prior notice.

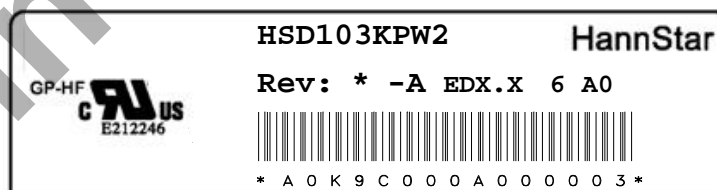

Document Title	HSD103KPW2-A10 Formal Specification	Page No.	24 / 26
Document No.	DC140-002952	Revision	1.0

10.0 PACKAGE SPECIFICATION

10.1 Packing form

LCM Model	Qty. in the Box	Inner Box Size(mm)	Notice
HSD103KPW2-A10	20 pcs/Box	Ref. 456 x 350 x 312 ^H	--

10.2 Packing assembly drawings

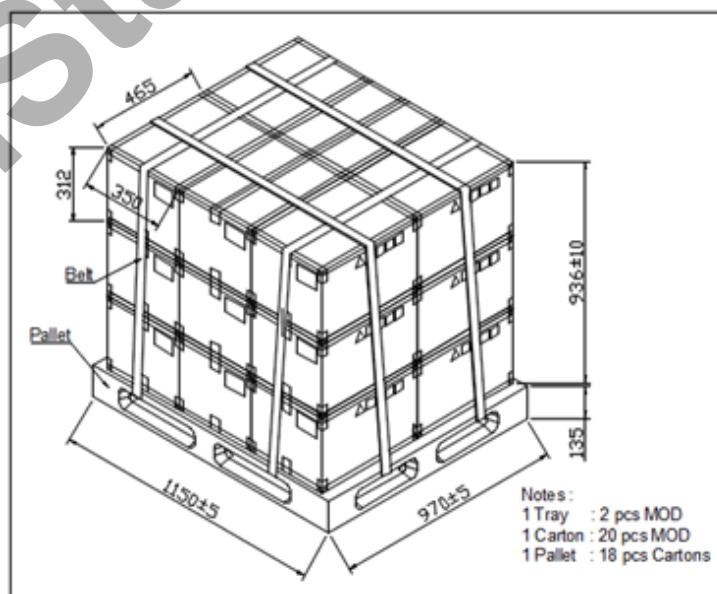
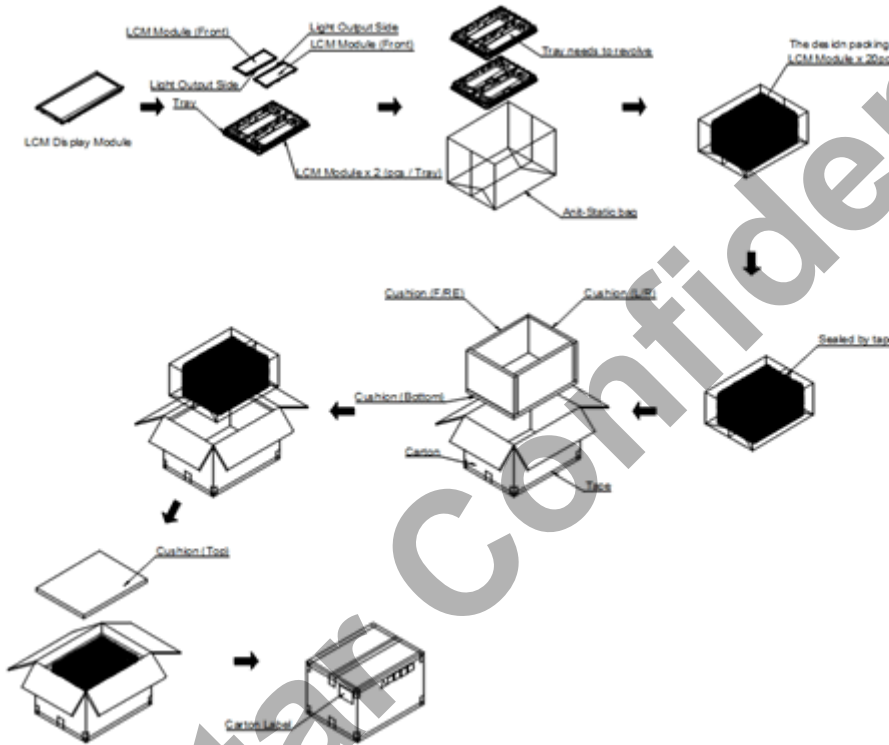

Document Title	HSD103KPW2-A10 Formal Specification	Page No.	25 / 26
Document No.	DC140-002952	Revision	1.0

11.0 GENERAL PRECAUTION

11.1 Use Restriction

This product is not authorized for use in life supporting systems, aircraft navigation control systems, military systems and any other application where performance failure could be life-threatening or otherwise catastrophic.

11.2 Disassembling or Modification

Do not disassemble or modify the module. It may damage sensitive parts inside LCD module, and may cause scratches or dust on the display. HannStar does not warrant the module, if customers disassemble or modify the module.

11.3 Breakage of LCD Panel

11.3.1. If LCD panel is broken and liquid crystal spills out, do not ingest or inhale liquid crystal, and do not contact liquid crystal with skin.

11.3.2. If liquid crystal contacts mouth or eyes, rinse out with water immediately.

11.3.3. If liquid crystal contacts skin or cloths, wash it off immediately with alcohol and rinse thoroughly with water.

11.3.4. Handle carefully with chips of glass that may cause injury, when the glass is broken.

11.4 Electric Shock

11.4.1. Disconnect power supply before handling LCD module.

11.4.2. Do not pull or fold the LED cable.

11.4.3. Do not touch the parts inside LCD modules and the fluorescent LED's connector or cables in order to prevent electric shock.

11.5 Absolute Maximum Ratings and Power Protection Circuit

11.5.1. Do not exceed the absolute maximum rating values, such as the supply voltage variation, input voltage variation, variation in parts' parameters, environmental temperature, etc., otherwise LCD module may be damaged.

11.5.2. Please do not leave LCD module in the environment of high humidity and high temperature for a long time.

11.5.3. It's recommended to employ protection circuit for power supply.

11.6 Operation

11.6.1 Do not touch, push or rub the polarizer with anything harder than HB pencil lead.

11.6.2 Use fingerstalls of soft gloves in order to keep clean display quality, when persons handle the LCD module for incoming inspection or assembly.

11.6.3 When the surface is dusty, please wipe gently with absorbent cotton or other soft material.

Document Title	HSD103KPW2-A10 Formal Specification	Page No.	26 / 26
Document No.	DC140-002952	Revision	1.0

11.6.4 Wipe off saliva or water drops as soon as possible. If saliva or water drops contact with polarizer for a long time, they may causes deformation or color fading.

11.6.5 When cleaning the adhesives, please use absorbent cotton wetted with a little petroleum benzine or other adequate solvent.

11.7 Mechanism

Please mount LCD module by using mounting holes arranged in four corners tightly.

11.8 Static Electricity

11.8.1 Protection film must remove very slowly from the surface of LCD module to prevent from electrostatic occurrence.

11.8.2 Because LCD module use CMOS-IC on circuit board and TFT-LCD panel, it is very weak to electrostatic discharge. Please be careful with electrostatic discharge. Persons who handle the module should be grounded through adequate methods.

11.9 Strong Light Exposure

The module shall not be exposed under strong light such as direct sunlight. Otherwise, display characteristics may be changed.

11.10 Disposal

When disposing LCD module, obey the local environmental regulations.